

CONTENTS

1 General Information	3
1.1  Safety Instructions	3
1.2 Switching the Operating Voltage 230 V~/115 V~	3
1.3 Mains Connection	4
1.4 Installing the Unit	4
1.5 Switching on	4
1.6 EMC	4
1.7 Inspection and Maintenance	4
1.8 Warranty	5
1.9 Delivered Accessories	5
2 Application	6
3 Configuration and Functional Description	7
3.1 Block Diagram	7
3.2 Description	8
4 Technical Data	9
4.1 General Data	9
4.2 Specification	9
4.3 Measuring Range of Parameters	10
4.4 Measuring Tolerances of Measuring Ranges	10
4.5 Display	11
4.6 Remote Control	11
5 Control Elements	13
6 Performance of Measurements	15
6.1 Starting	15
6.2 Operation of the Unit	16
6.3 Measuring Functions	16
6.3.1 RLC Measurement	16
6.3.2 Measuring Additional Parameters Q and D	17
6.3.3 Tolerance Measurement	18
6.3.3.1 <i>Entering the Reference Value</i>	18
6.3.3.2 <i>Absolute Tolerance Measurement</i>	19
6.3.3.3 <i>Relative Tolerance Measurement</i>	19
6.4 Operating Parameters	20
6.4.1 Parallel or Series Connection	20
6.4.2 Selecting the Measuring Range	21

6.5 Residual Parameters of the Terminals	21
6.5.1 Operating Mode Trim On	22
6.5.2 Operating Mode Trim Off	23
6.6 Polarization of the Measuring Object	23
6.7 Service Menu	24
6.7.1 Self Diagnosis of the Unit	24
6.7.2 Special Instrument Functions	24
7 Remote Control by Program	25
7.1 Preparation of the Unit	25
7.1.1 Selecting Transmission Parameters	25
7.1.1.1 <i>Baud Rate</i>	25
7.1.1.2 <i>Transmission Protocol</i>	26
7.1.2 Remote Control \Leftrightarrow Local Control	27
7.2 Messages of the Unit on Remote Control	27
7.2.1 Description of the Unit Status	27
7.2.1.1 <i>ESR - EVENT STATUS REGISTER</i>	27
7.2.1.2 <i>STB - STATUS BYTE REGISTER</i>	28
7.2.2 Description of Results	29
7.2.3 Description of Errors	29
7.2.3.1 <i>DER - DEVICE ERROR REGISTER</i>	30
7.2.3.2 <i>Error Messages</i>	30
7.3 List of Commands on Remote Control	31
7.3.1 General Commands	31
7.3.2 Commands and Messages	33
7.4 Measurement by Remote Control	35
7.5 Program Example (Q-Basic)	36
8 Maintenance	37
9 Appendix	38
9.1 Declaration of Conformity	38

1 General Information

1.1 Safety Instructions

Wherever you see this sign  you will find information on potential hazards. Please read these sections with particular care!

 **Warning!** Before opening the unit disconnect the mains plug!

 **Attention!** Our instrument fuses are dimensioned in such a way that optimal protection is guaranteed for the instrument and the user. In industrial power supplies, which are extremely strongly loaded, the instrument fuses could respond sporadically due to high voltage peaks. If the fuse has to be changed, use only G fuse-link 5×20 according to IEC 127 (See 4.1)!

1.2 Switching the Operating Voltage 230 V~/115 V~

Your RLC 100 left the factory to 230 V~. Switching to 115 V~ requires the RLC 100 to be opened, which should only be done by trained personnel.

Setting the Operating Voltage 115 V~

1. Disconnect the RLC 100 from the mains.
2. Remove upper caps and loosen the screws below.
3. Identify the mains voltage switch with the following illustration.
4. Switch the voltage mains voltage switch (slide switch) located under the power switch to the indication “120”.
5. Remove safety cover at the mains plug and replace the fuse with the fuse for 115 V supplied with the instrument.
6. Fasten upper caps and put the sticker supplied with the instrument for marking the switch-over to 115 V on to the type label.

Mains Voltage Switch



115 V Position



230 V Position

1.3 Mains Connection

The design of the unit meets the requirements of safety class I according to EN 61010-1, i.e. all metal parts accessible from outside and exposed to contact are connected with the protective conducto of the supply network.

Power is supplied via a mains cable with earthing contact.

1.4 Installing the Unit

The RLC 100 should not be operated close to equipment that develops heat.

1.5 Switching on

The RLC 100 is switched on using the power switch at the front. The power switch separates the RLC 100 completely from the primary side of the transformer.

The LED *ON/OFF* serves as a status indicator.

1.6 EMC

The RLC 100 is interference-free according to EN 50081-1 and EN 50081-2. In order to fulfil the limiting values in line with present standards, it is absolutely essential that only cables which are in perfect condition be connected to the unit. The following information applies here:

- Metallic or metallized socket cases must be used for the serial interface RS-232C. The socket cases and the braided screen of the cables must be connected at the shortest distance possible. The signal earth must not be connected to the braided screen.
- After opening and closing the RLC 100 it should be checked that all the fixing parts and contact springs are installed as before that all the screws are fixed tightly.

1.7 Inspection and Maintenance

If service is needed, due attention should be paid to the regulations according to VDE 0701. The RLC 100 should only be repaired by trained personnel.

1.8 Warranty

GRUNDIG guarantees the perfect working order of the RLC 100 for 12 months as from delivery.

There is no warranty for faults arising from improper operation or from changes made to the unit or from inappropriate application.

If a fault occurs please contact or send your RLC 100 to:

The RLC 100 should be sent in appropriate packing - if possible in the original packing. Please enclose a detailed fault report (functions working incorrectly, deviating specifications and so on) including unit type and series number.

Kindly verify warranty cases by enclosing your supply delivery note. Any repairs carried out without reference to a valid warranty will initially be at the owner's expense.

Should the warranty have expired, we will, of course, be glad to repair your RLC 100 as per our General Terms Of Assembly And Service.

1.9 Delivered Accessories

- 1 mains cable
- 1 measuring cable 1AF 805 15
- 1 fine-wire fuse T 63 L/250 V (230 V)
- 2 fine-wire fuses T 125 L/250 V (115 V)
- 1 operating instructions
- 1 label for indicating the switch-over to 115 V

2 Application

- The automatic RLC meter RLC 100 is a measuring instrument controlled by a microprocessor which is suitable for fast and exact measuring of R, L, C, D and Q parameters of passive and active components. The basic error is 0.5 %. The measuring frequency is 1 kHz and the measuring voltage is smaller than 2 V.
In addition to the above mentioned parameters component tolerances can be determined in absolute and relative terms.
The functions of the instrument are checked with the help of the internal test (self diagnosis).
- The measuring objects are connected to the RLC 100 by a four-wire line with Kelvin terminals. The effect of stray capacitances, lead inductances and contact resistance is thus substantially reduced. The residual capacitance of the measuring adapter can be compensated (See 6.5).
- In response to the connected impedance, the RLC 100 automatically recognises the measuring object and the measuring range and allows the parameters to be determined using the series and parallel equivalent circuit diagram of the measuring object.
With the help of the *Range Hold* function (See 6.4.2) the automatic selection of the measuring range can also be switched off.
- The polarization voltage of approx. 2 V (e.g. to measure electrolyte condensers) can be supplied from an internal voltage source (See 6.6).
- The RLC 100 is operated by four buttons, each of which has several functions. The measuring functions can be selected directly. Special functions and parameter settings are menu-controlled.
The function and parameter settings are clearly depicted on a 16-digit alphanumerical LC matrix display.
- As standard the RLC 100 is supplied with a serial interface RS-232C for communication with superior systems. All functions and parameters can be set, measurements can be executed and measured values and statuses of the RLC 100 can be transmitted.

3 Configuration and Functional Description

3.1 Block Diagram

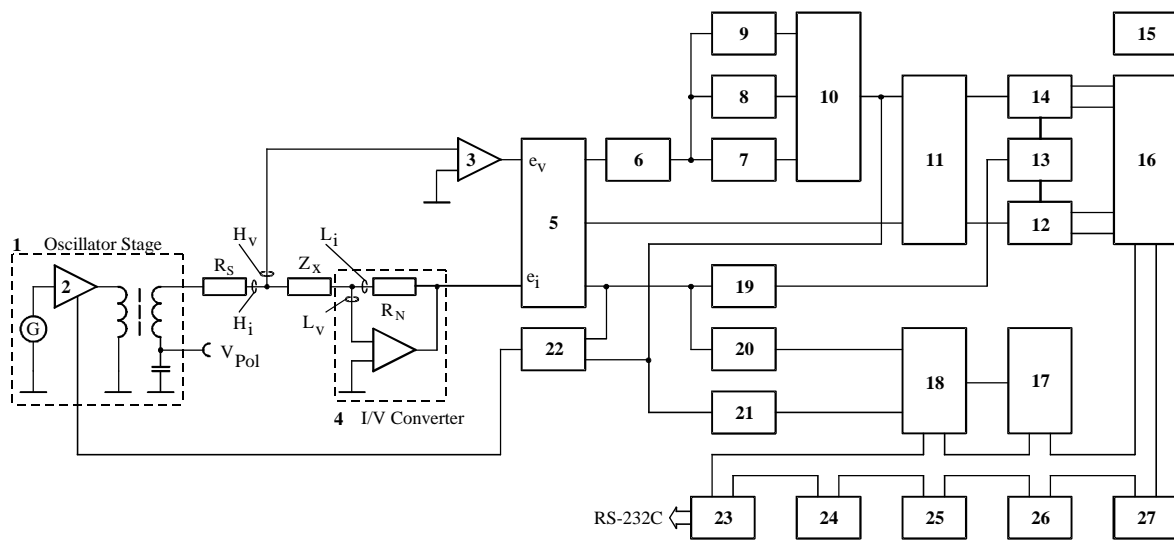

Fig. 1: Block diagram

- (1) Measuring signal generator 1 kHz
- (2) Current-controlled amplifier
- (3) Voltage amplifier 1×, 10×, 100×
- (4) I/V converter
- (5) Switch of the input signals
- (6) Amplifier 1×, 10×
- (7) Phase shifter $-3/2\pi$
- (8) Phase shifter $-\pi$ (inverting amplifier)
- (9) Phase shifter $-\pi/2$
- (10) Switch for selection of the phase shifter
- (11) Switch for selection of the input signal of measuring channel and reference channel
- (12) Synchronous detector of the reference channel
- (13) Controlled inverter
- (14) Synchronous detector of the measuring channel
- (15) Power supply
- (16) A/D converter
- (17) Control logic
- (18) Microprocessor
- (19) Comparator
- (20) Comparator
- (21) Comparator
- (22) Summing amplifier
- (23) Serial interface RS-232C
- (24) Keyboard
- (25) LC display
- (26) EPROM program memory
- (27) RAM data memory

3.2 Description

The internal measuring sequence is controlled by the one-chip microprocessor MCS-51 (18) with the help of additional circuits, e.g., program memory (26) and RAM data memory (27). When measuring, the system parameters R, L, C, D and Q are derived from the voltage at the measuring object (impedance Z_X) and from the current passing through the measuring object.

When the generator signal is defined, the measuring object Z_X is supplied by the oscillator with amplitude control (1, 2), the dividing transformer, and the resistor R_S .

The voltage e_v picked off by the measuring object Z_X , is determined directly with the help of the operating amplifier (3). The voltage e_i , which is proportional to the current passing through the measuring object Z_X is supplied by the I/V converter (4). The appropriate measuring range is set using the standardised resistor R_N of the I/V converter (4) and the amplification of the operating amplifier (3).

The voltage values e_v and e_i are led in turn to the synchronous detectors (12, 14) via the phase shifters (7, 8, 9). The synchronous detectors (12, 14) determine the real and imaginary components of the voltage and current vectors of the measuring object Z_X with the help of the phase reference. The rectified voltages $|e_v|$ and $|e_i|$ are led to the measuring and reference inputs of the A/D converter (16) and the voltage ratio $e_v / |e_i|$ is generated.

The phase reference signal for the synchronous detectors [12, 14] is determined by the generator signal (voltage and current) with the help of the comparator (19) and the inverter (13) which is supplied by the measuring object Z_X . The measuring signal results from the equivalent connection (series or parallel) which is selected.

The processor is informed by the comparators (20, 21) when the input circuit is overloaded in the present measuring range and when the phase reference signal is undershot.

The activated measuring function and the selected measuring range are set by the processor (18) by means of the control logic (17) and the switches (5, 10, 11).

The processor (18) can communicate with superior systems via the serial interface RS-232C. (23). The instrument is operated via the keyboard (24) and the display (25).

4 Technical Data

4.1 General Data

Nominal temperature:	+ 23 °C ± 1 °C
Operating temperature:	+ 5 to + 40 °C
Relative humidity:	20 to 80 %
Atmospheric pressure:	70 to 106 kPa
Operating position:	horizontal or inclined by ± 15 °
Operating voltage:	sinusoidal alternating voltage (distortion factor < 5 %) 115/230 V (+ 10 %/– 15 %), internal switchable, 50 to 60 Hz (± 5 %)
Power consumption:	max. 8 W
Fuses:	T 63 L/250 V (230 V~) T 125 L/250 V (115 V~)
Safety class:	I, according to EN 61010 Part 1
Radio interference suppression:	EN 55011 Class B
Dimensions (L × H × D):	225 mm × 85 mm × 200 mm
Dimensions of packing:	310 mm × 110 mm × 265 mm
Weight of	
RLC 100:	approx. 1.8 kg
incl. packing and accessories:	approx. 2.6 kg

4.2 Specification

Measuring parameters:	R, L, C, Q (D), Δ , δ
Equivalent connection:	series or parallel connection
Connection of the measuring object:	four-wire line with Kelvin terminals
Measuring frequencies:	1 kHz ± 3 %
Measuring voltages:	< 2 V
Selection of measuring range:	automatically or within fixed range
Polarization of the measuring object:	internal voltage source, approx. 2 V
Measuring time:	max 400 ms for R, L, C, Δ , δ approx. 1.2 s for Q (D) in the fixed range

4.3 Measuring Range of Parameters

Measuring parameters	Measuring range	
	from	to
R	1 mΩ	1.999 MΩ
L	0.1 μH	199.9 H
C	0.1 pF	1.999 mF
Q _R	0.001	> 1.200
Q _L	< 1.0	199
D _C	0.001	> 1.200
δ	- 100.0 %	+ 199.9 %

Table 1: Measuring range of parameters

4.4 Measuring Tolerances of Measuring Ranges

Equivalent connection	Series connection					Parallel connection		
	0	1	2	3	4	5	6	7
Measuring range R [Ω]	-	2	20	200	2 k	20 k	200 k	2 M
Measuring error R	-	± 2 % ± 3 dig	± 1 % ± 3 dig	± 0.5 % ± 2 dig		± 1 % ± 2 dig		± 2 % ± 3 dig
Measuring error Q	-	± 3 % ± 0.01	± 3 % ± 0.005	± 2 % ± 0.005	± 2 % ± 0.005	± 2 % ± 0.005	± 3 % ± 0.005	± 3 % ± 0.008

Additional error for R measurement in response to Q: $0.5 \times Q$ [%]

Table 2: Measuring Tolerances of R measurement

Equivalent connection	Series connection					Parallel connection		
	0	1	2	3	4	5	6	7
Measuring range L [H]	-	200 μ	2 m	20 m	200 m	2	20	200
Measuring error L	-	± 2 % ± 3 dig	± 1 % ± 3 dig	± 0.5 % ± 2 dig		± 1 % ± 2 dig		± 2 % ± 3 dig
Measuring error Q	-	± 10 % ± 2 dig	± 10 % ± 1 dig			± 10 % ± 2 dig		± 10 % ± 2 dig

Additional error for L measurement in response to Q: $0.5 / Q$ [%]

Is not specified for $Q > 50$.

Table 3: Measuring Tolerances of L measurement

Equivalent connection	Series connection					Parallel connection		
Measuring range C [F]	0 2 m	1 200 μ	2 20 μ	3 2 μ	4 200 n	5 20 n	6 2 n	7 200 p
Measuring error C	± 2 % ± 8 dig	± 2 % ± 5 dig	± 1 % ± 3 dig	± 0.5 % ± 2 dig		± 1 % ± 2 dig		± 2 % ± 3 dig
Measuring error D	no specif.	± 3 % ± 0.01	± 2 % ± 0.005	± 2 % ± 0.005	± 2 % ± 0.005	± 2 % ± 0.005	± 2 % ± 0.005	± 3 % ± 0.01

Additional error for C measurement in response to D: $0.5 \times D$ [%]

The measuring error for D measurement is specified only when $C \geq 100$ pF.

Table 4: Measuring Tolerances of D measurement

Note: The specific measuring tolerances are indicated at a nominal temperature of $23\text{ °C} \pm 2\text{ °C}$. The measuring tolerances are raised by 50 % per 10 °C deviation in the range of the operating temperature.
The measuring tolerances apply to measuring value displays greater than 10 % of the measuring range i.e. for displays in the range of 200 to 1999. The following conditions must be fulfilled at the same time:

$D_C < 1$, $Q_R < 1$ or $Q_L > 1$ and $C < 200$ pF (referring to ground).

4.5 Display

The RLC 100 is equipped with a 16-digit alphanumerical LC matrix display with lighting. It indicates measuring parameters, operating modes, measuring values with the current measuring unit as well as the functions by menu and system messages.

4.6 Remote Control

The RLC 100 can be fully controlled and can be read out via the serial interface RS-232C.

Data transmission rate:	1,200 to 9,600 Bd
Length of data character:	8 bit
Number of STOP bits:	1
Parity:	none
Protocol:	RTS/CTS, without (NONE)
End characters on receiving:	LF (10 dec.)
End characters on transmission:	CR + LF (13 dec. + 10 dec.)
Length of input buffer:	64 characters
Length of output buffer:	256 characters

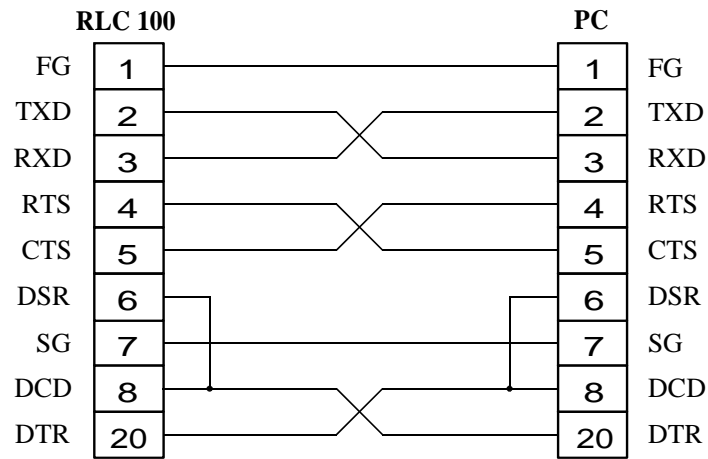

Fig. 2: *Plug connections*

5 Control Elements

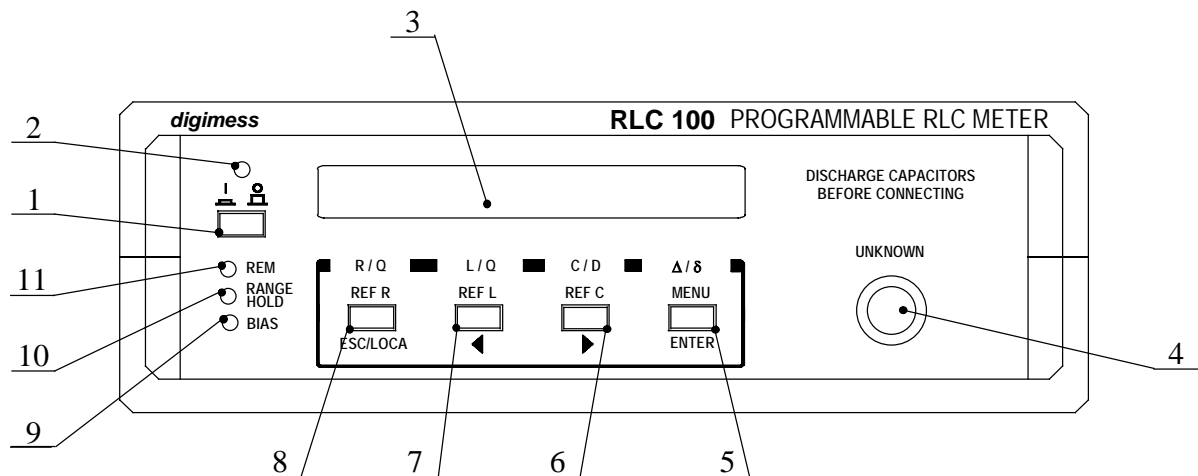

Fig. 3: Control elements

- [1] **Power switch**
- [2] **LED ON/OFF**
The LED indicates whether the unit is ready for operation.
- [3] **LC display**
see 4.5
- [4] **Input socket**
- [5] **Function button with multi-setting reservation:**
 - ❶ **Δ/δ**
selection of the tolerance measurement
 - ❷ **MENU**
selection in the setting menu
 - ❸ **ENTER**
confirming the settings in the current menu
- [6] **Function button with multi-setting reservation:**
 - ❶ **C/D**
selection of the capacity parameter (C, D) to be measured
 - ❷ **REF C**
input of the reference signal during tolerance measurement of the capacity C
 - ❸ **⇨**
The cursor is moved to the right.

-
- [7] **Function button with multi-setting reservation:**
- ❶ **L/Q**
selection of the inductance parameter (L, Q) to be measured
 - ❷ **REF L**
input of the reference signal during tolerance measurement of the inductance L
 - ❸ **←**
The cursor is moved to the left.
- [8] **Function button with multi-setting reservation:**
- ❶ **R/Q**
selection of the resistance parameter (R, Q) to be measured
 - ❷ **REF R**
input of the reference signal during tolerance measurement of the resistor R
 - ❸ **ESC/LOCAL**
leaving the menu level without changing settings
transition from remote control to local control
- [9] **LED BIAS**
Indicates that the internal voltage for the polarization of the measuring object has been connected.
- [10] **LED RANGE HOLD**
Indicates if a fixed range is set.
- [11] **LED REM**
The LED lights up if data are sent via serial interface RS-232C.

The power is supplied by a **fused plug for non-heating appliances**. The RLC 100 is protected by a fuse of T 63 L/250 V for 230 V~ or T 125 L/250 V for 115 V~ net voltage respectively. The **operating voltage indication** shows which operating voltage is to be used. The serial interface **RS-232C** serves the purpose of data transmission on remote control via a PC.

The mains plug with fuse, the operating voltage indication, the serial interface RS-232C and the **type plate** can be found at the back of the RLC 100.

6 Performance of Measurements

6.1 Starting



Attention!

When the RLC 100 is operated externally, the connecting cable of the system interface RS-232C must be connected before switching on the operating voltage.

- The RLC 100 is connected to the power supply by the mains cable. After activating the power switch [1], the LED *ON/OFF* [2] lights up and an internal test starts up. The following message appears on the display [3]:

```
Testing... UNIT
```

The variable *UNIT* stands for the unit which has just been tested. The appropriate functions of the processor (CPU), the ROM memory (ROM), the RAM memory (RAM), the display (LCD), the keyboard (KEYB) and the serial interface (RS 232) are checked. On error-free conclusion of the test the following confirmation and current software version appear:

```
<RLC100> READY
```

```
Version: 1.04
```

- After error-free testing, the settings correspond to those of the original state of operation:
 - Resistance measurement,
 - Automatic selection of measuring mode,
 - Disconnected polarisation voltage,
 - Baud rate - 9600 Bd,
 - Transmission protocol - none (NONE).

The RLC 100 continuously displays the measured resistance value. If a measuring impedance is not connected the following message appears:

```
Rp: Overflow
```

- Should a system error occur during the internal test, the RLC 100 interrupts the test until the error is eliminated. The following messages appear on the display [3]:

```
UNIT Error
```

```
System HALTED!
```

- If errors which have no direct effect on the function of the RLC 100 occur in the component circuits, the test will continue. The following message appears on the display [3]:

RS 232 Error

6.2 Operation of the Unit

The RLC 100 is operated by four function buttons [5], [6], [7] and [8], which operate on three levels.

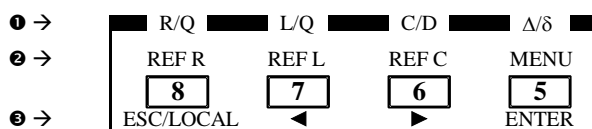

Fig. 4: Button meanings

- ❶ Function level - is activated by pressing the corresponding function button **briefly**.
- ❷ Function level - is activated by pressing the corresponding function button for a **longer** period ($t > 1$ s).
- ❸ After activating the second function level the buttons get an alternative meaning.

Note: In the following paragraphs the function buttons are referred to directly by the function to be executed e.g. “Selection of resistance measuring with the R/Q button [8]”.

6.3 Measuring Functions

6.3.1 RLC Measurement

The measuring object is connected to the RLC 100 by the measuring cable (four-wire line with Kelvin terminals). The effect of stray capacities, lead inductances and contact resistances is thus substantially reduced.

- Select the corresponding measuring function R, L or C by pressing the R/Q button [8], L/Q button [7] or the C/D button [6] briefly. The RLC 100 sets the optimal measuring range automatically and executes a measurement of the main parameters. The measurement value is depicted on the display [3] as follows, e.g.:

Ls: 90.1μH

A selected measuring range can also be kept (See 6.4.2).



Negative display of the Instrument

A negative display occurs on measurements of objects with a predominant reactance component (capacitors, inductances) if the selected measuring function is indirectly connected to the measuring object. So, for instance, if a capacitor C is connected to the measuring lines for the L measurement or if an inductance L is connected to the measuring lines for the C measurement, the unit displays an equivalent reactance according to the equation:

$$L_S = -\frac{1}{(2\pi f)^2 C_S} \quad \text{or} \quad C_P = -\frac{1}{(2\pi f)^2 L_P}.$$

Where: L_S - series inductance L_P - parallel inductance
 C_S - series capacitance C_P - parallel capacitance

When measuring with a negative display, a measuring frequency tolerance of $\pm 3\%$ must be taken into consideration.

6.3.2 Measuring Additional Parameters Q and D

The measuring object is connected to the RLC 100 by the measuring cable.

- Select the corresponding measuring function - quality measurement Q for resistors and coils, or loss factor measurement D for condensers by briefly pressing the R/Q button [8], L/Q button [7] or the C/D button [6] twice. The RLC 100 sets the optimal measuring range automatically and executes a measurement of the main parameters. The measurement value is depicted on the display [3] as follows, e.g.:

Q L _S : 4.3

Note: The optimal measuring range is determined when measuring the main parameter R, L or C. The measuring speed is thus fixed to approx. 1 s.

The loss component of the measuring impedance, e.g. the **series resistance of a coil** can also be displayed.

- Select the corresponding measuring function R, L or C by pressing the R/Q button [8], **L/Q button [7]** or the C/D button [6]. After automatic measurement of the main parameter, switch the measuring range from Range Auto to Range Hold (See 6.4.2). Now briefly press the **R/Q button [8]**, L/Q button [7] or the C/D button [6], in order to determine the loss components and the following appears on the display [3], e.g.:

R _S : 0.123 Ω

Note: It is possible to switch between measuring the main parameters R, L, C or the additional parameters Q, D by pressing R/Q button [8], L/Q button [7] or the C/D button [6] briefly.

6.3.3 Tolerance Measurement

The RLC 100 can determine the absolute (Δ) and relative (δ) deviation of an R, L or C value in relation to a reference value. The control value (reference value) must be entered before tolerance can be measured.

6.3.3.1 Entering the Reference Value

The measuring object, from which the reference value is to be determined, is connected to the RLC 100 by the measuring cable.

- After pressing the REF R button [8], REF L button [7] or the REF C button [6] for a longer period, the second level is reached by entering the corresponding reference value and the following appears in the display [3]:

REF :

The RLC 100 measures the connected impedance Z_x and displays the measuring results as follows, e.g.:

REF : 1.000 k Ω

- The reference values in the present measuring range of 0001 to 1999 can be changed with the help of the cursor buttons \Leftarrow [7] and \Rightarrow [6]. After pressing ENTER [5] the reference value is saved as a control value for purposes of tolerance measurement.

If the RLC 100 do not know the reference value, the following message appears on the display [3]:

Value ignored!

Each new entry of the reference value (R, L or C value) clears the corresponding previous reference value in the memory. Should the former state be kept, press ESC button [8]. After switching off the RLC 100 all reference values are cleared.

Note: If a negative measuring value is displayed (See 6.3.1), the reference value in the current measuring range of -1999 to -0001 can be changed with the help of the cursor buttons \Leftarrow [7] and \Rightarrow [6].

6.3.3.2 Absolute Tolerance Measurement

- Select the corresponding measuring function R, L or C by pressing the R/Q button [8], L/Q button [7] or the C/D button [6] briefly. The RLC 100 sets the optimal measuring range automatically and executes a measurement of the main parameters. The measured value is depicted on the display [3] as follows, e.g.:

RS: 1.109 kΩ

- After pressing the Δ/δ button [5] briefly, the measured value is displayed as an absolute deviation from the control value (saved reference value), e.g.:

Δ RS: 0.109 kΩ

- The absolute deviation is derived from the following:

$$\Delta = M - R \quad \text{or} \quad \Delta = M' - R$$

Where:

Δ - Absolute deviation

M - Measured value

M' - Measured value diminished by the influence of the residual parameters of the terminals (See 6.5)

R - Reference value

Note: With the help of the Δ/δ button [5] it is possible to switch between measuring absolute and relative tolerances of the measured value.

6.3.3.3 Relative Tolerance Measurement

- Select the corresponding measuring function R, L or C by pressing the R/Q button [8], L/Q button [7] or the C/D button [6] briefly. The RLC 100 sets the optimal measuring range automatically and executes a measurement of the main parameters. The measured value is depicted on the display [3] as follows, e.g.:

RS: 1.109 kΩ

- After briefly pressing the Δ/δ button [5] twice, the measured value is displayed as an relative deviation from the control value (saved reference value), e.g.:

δ RS: 10.9 %

- The relative deviation is derived from the following:

$$\delta = \left(\frac{M}{R} - 1 \right) \cdot 100 \quad \text{or} \quad \delta = \left(\frac{M'}{R} - 1 \right) \cdot 100$$

Where:

- δ - Relative deviation in per cent
- M - Measured value
- M' - Measured value diminished by the influence of the residual parameters of the terminals (See 6.5)
- R - Reference value

All reference values are cleared after switching on the RLC 100. If the relative tolerance measurement is executed without any previous entry of a reference value, the following message appears on the display [3]:

δR_p : Overflow

Note: With the help of the Δ/δ button [5] it is possible to switch between measuring absolute and relative tolerances of the measured value.

6.4 Operating Parameters

6.4.1 Parallel or Series Connection

The measuring object generally has a complex character and the equivalent connection can be depicted as parallel or series connection of the real and imaginary components. With regard to optimal measuring conditions, the unit measures high impedances with constant voltage V_p (parallel connection) and low impedances with constant current I_s (series connection).



Fig. 5: *Series connection*

Parallel connection

6.4.2 Selecting the Measuring Range

After switching on, the instrument sets itself for automatic selection of the measuring range. During the automatic selection of the measuring range, a continuous series of “little stars” appears on the display. The number of “little stars” (1 to 8) corresponds to the measuring range which is in operation at the time (See 4.3).

On repeated measurements of the object with approximately the same values and using a polarization voltage (See 6.6) it is advisable to use the same measuring range. Here the measuring time is shortened as the automatic selection of the optimum measuring range does not take place.

- By pressing the MENU button [5] for a long time the main menu is reached and the following message appears on the display [3]:

Range Bias Trim>

- Select the position Range with the help of the cursor buttons \Leftarrow [7] and \Rightarrow [6]. After pushing the ENTER button [5] the current selection of the measuring range is displayed, e.g.:

Range: Hold

- Select the position Range Auto or Range Hold with the help of the cursor buttons \Leftarrow [7] and \Rightarrow [6].
The operating mode Range Hold is signalled via the LED *RANGE HOLD* [10].
- Save the new setting with the ENTER button [5]. If the former state is to be kept, press the ESC button [8]. In both cases the RLC 100 reverts to the main menu. On pressing the ESC button [8] repeatedly the main menu is left and the RLC 100 starts the measurements.

Note: If a measuring object, whose impedance exceeds the set measuring range, is connected during the operating mode Range Hold or the measuring range is not found for the connected measuring impedance during the operating mode Range Auto, the following error message appears: e.g., on R measurement.

R_p: Out of RNG

6.5 Residual Parameters of the Terminals

The measuring signals are tapped off by a four-wire line with Kelvin terminals in order to minimize the influence of the residual parameters. However, a complete elimination of the residual parameters is impossible as the influence of the contact points of the terminals becomes apparent. When the terminals are load free, the RLC 100 indicates a residual capacity C_{rest} and in the case of a short circuit of the terminals it indicates the residual resistance R_{Rest} and the residual inductance L_{Rest} .

On R and L measurements of lower values, the residual parameters R_{Rest} and L_{Rest} should be deducted from the measured value. The compensation of the residual capacity C_{Rest} can be carried out automatically with the help of the *Trim* function.

- By pressing the MENU button [5] for a long time the main menu is adjusted and the following message appears on the display [3]:

```
Range Bias Trim>
```

- Select the position Trim with the help of the cursor buttons \leftarrow [7] and \rightarrow [6]. After pushing the ENTER button [5] the *Trim* function is called on.
 - If the measuring function C measurement is set, the current selection of the *Trim* function is displayed, e.g.:

```
Trim: On
```

Set the operating mode Trim On or Trim Off with the help of the cursor buttons \leftarrow [7] and \rightarrow [6].

- If the measuring functions R or L measurement are set, the following message appears on the display [3]:

```
Trim: None
```

6.5.1 Operating Mode Trim On

- Set the operating mode Trim On (See 6.5). After pressing the ENTER button [5] the residual capacity of the terminals is compensated and the following message appears on the display [3], e.g.:

```
Trim: 0.4 pF
```

If the residual capacity is greater than $C_{rest} = 100$ pF, the following message appears:

```
Trim: Overflow
```

- By pressing the ESC button [8] or ENTER button [5] the RLC 100 reverts to the main menu. On pressing the ESC button [8] repeatedly the main menu is left and the RLC 100 starts the measurements.
- The operating mode Trim On is indicated by the symbol T in the last position of the display [3]:

```
Cp: 0.0 pF T
```

The displayed measured value is derived from the following:

$$C' = C - C_{\text{Rest}}$$

Where:

- C' - displayed capacity
- C - measured capacity
- C_{Rest} - residual capacity of the terminals

6.5.2 Operating Mode Trim Off

- Set the operating mode Trim Off (See 6.5). After pressing the ENTER button [5] the residual capacity compensation of the terminals is deactivated and the RLC 100 reverts to the main menu. On pressing the ESC button [8] repeatedly the main menu is left and the RLC 100 starts the measurements.

6.6 Polarization of the Measuring Object

The polarization of the measuring object (capacity measurement) can be handled internally $V_{\text{BIAS}} = +2\text{ V}$ with the help of the measuring cable.

 **Attention!** Care must be taken to ensure the correct terminal is connected when polarizing the measuring object. The terminal with positive voltage is red.

- By pressing the MENU button [5] for a long time the main menu is reached and the following message appears on the display [3]:

```
Range Bias Trim>
```

- Select the position Bias with the help of the cursor buttons \leftarrow [7] and \rightarrow [6]. After pushing the ENTER button [5] the current settings of the polarisation voltage is displayed, e.g.:

```
Bias:           On
```

- Set the operating mode Bias On or Bias Off with the help of the cursor buttons \leftarrow [7] and \rightarrow [6].
The operating mode Bias On is signalled via the LED BIAS [9].
- Save the new setting with the ENTER button [5]. If the former state is to be kept, press the ESC button [8]. In both cases the RLC 100 reverts to the main menu. On pressing the ESC button [8] repeatedly the main menu is left and the RLC 100 starts the measurements.

6.7 Service Menu

Tests for self-diagnosis of the RLC 100 and special functions e.g., calibration, can be set by the service menu.

- By pressing the MENU button [5] for a long time the main menu is reached and the following message appears on the display [3]:

```
< Int  Service
```

- Select the position `Service` with the help of the cursor buttons \leftarrow [7] and \rightarrow [6]. After pushing the ENTER button [5] the service menu is displayed.

```
Test  Special
```

6.7.1 Self Diagnosis of the Unit

- Call up the service menu (See 6.7). Select the position `Test` with the help of the cursor buttons \leftarrow [7] and \rightarrow [6]. After pressing the ENTER button [5] special tests for the self-diagnosis test are started.

Service adaptors are needed for the self-diagnosis test.

After successful completion of the test, the RLC 100 reverts to the service menu. To exit the service menu press the ESC button [8].

6.7.2 Special Instrument Functions

- Call up the service menu (See 6.7). Select the position `Special` with the help of the cursor buttons \leftarrow [7] and \rightarrow [6]. After pressing the ENTER button [5] a request for a password appears on the display [3]:

```
Password: 000000
```

- Enter the password. After pressing the ENTER button [5] special menus for service and calibrating settings are activated.

7 Remote Control by Program

7.1 Preparation of the Unit

Remote control of the RLC 100 with a personal computer (PC) is possible via the serial interfaces RS-232C. The interface of the personal computer must be configured as described in paragraph 4.6. The connecting cable must not be longer than 15 m. Interface cables should be connected when the unit is off. After switching on the RLC 100 is in starting position and can receive commands. The remote control is displayed on LED *REM* [11].

7.1.1 Selecting Transmission Parameters

7.1.1.1 Baud Rate

After switching on the RLC 100 and after the following internal test is successfully completed the transmission parameters can be set by the menu.

- After pressing the MENU button [5] for a long time the main menu is reached and the following message appears on the display [3]:

< Int Service

- Select the position *Int* with the help of the cursor buttons ⇐ [7] and ⇒ [6]. After pressing the ENTER button [5] the sub-menu is reached and the following message appears on the display [3]:

Bd-Rate Protocol

- Select the position *Bd-Rate* with the help of the cursor buttons ⇐ [7] and ⇒ [6]. After pressing the ENTER button [5] the current baud rate is displayed, e.g.:

Bd-Rate: 9600

- Set the desired baud rate 1200, 2400, 4800 or 9600 by pressing the cursor buttons ⇐ [7] and ⇒ [6].
- Save the new setting with the ENTER button [5]. If the former state is to be kept, press the ESC button [8].
After pressing the ESC button [8] the main menu is left and the RLC 100 starts the measurements.

7.1.1.2 Transmission Protocol

- After pressing the MENU button [5] for a long time the main menu is reached and the following message appears on the display [3]:

< Int Service

- Select the position Int with the help of the cursor buttons ⇐ [7] and ⇒ [6]. After pressing the ENTER button [5] the sub-menu is reached and the following message appears on the display [3]:

Bd-Rate Protocol

- Select the position Protocol with the help of the cursor buttons ⇐ [7] and ⇒ [6]. After pressing the ENTER button [5] the current transmission protocol is displayed, e.g.:

Prot: None

- Set the desired transmission protocol NONE or RTS/CTS by pressing the cursor buttons ⇐ [7] and ⇒ [6].
- Save the new setting with the ENTER button [5]. If the former state is to be kept, press the ESC button [8].
After pressing the ESC button [8] the main menu is left and the RLC 100 starts the measurements.

Communication with RTS/CTS protocol

Data received from PC:	signal RTS=ON	- RLC 100 can receive data.
	signal RTS=OFF	- RLC 100 cannot receive data.
Data transmitted to PC:	signal CTS=ON	- RLC 100 transmits data.
	signal CTS=OFF	- RLC 100 does not transmit data.

Communication without RTS/CTS protocol

Data received from PC:	signal RTS=ON	- RLC 100 can always receive data, on overloading of the input buffer the error INP.BUFFER FULL is reported.
Data transmitted to PC:	signal CTS=ON	- RLC 100 can always transmit data.

7.1.2 Remote Control ⇔ Local Control

On transmission of the command `REN` from the personal computer the RLC 100 is in the `REMOTE CONTROL` status. This is indicated by the LED `REM` [11]. Afterwards control of the RLC 100 by the local control elements is not possible (except `LOCAL` button [8]).

- There are several ways of switching from remote control to local control:
 - by transmitting command `GTL` (Go To Local) from the personal computer,
 - by pressing the `LOCAL` button [8] at the RLC 100 if the keyboard has not been locked by the command `LLO` (Local Lock Out),
 - by switching off and on the power switch [1].

Note: Block the `LOCAL` button [8] with the help of the command `LLO`. Then all the commands of the PC are processed completely.

- The following commands can also be sent and received by the personal computer when the RLC 100 is on local control:

`*IDN?` , `*CLS` , `*ESR?` , `*ESE` , `*ESE?` , `*STB?` , `*SRE` , `*SRE?` , `ERR?` , `DER?`.

7.2 Messages of the Unit on Remote Control

7.2.1 Description of the Unit Status

The current status of the operating conditions of the RLC 100 can be interrogated at any time via the `EVENT STATUS REGISTER` and the `STATUS BYTE REGISTER`.

7.2.1.1 *ESR - EVENT STATUS REGISTER*

The contents of the `ESR` register are filed in the output buffer and deleted by transmitting the command `*ESR?`. The `ESR` register is set on \emptyset (except bit 7 - `PON`) when switching on the RLC 100 or after changing the interface parameters. By transmitting the command `*CLS` all bits are set on 1.

Contents of the `ESR` register: `ESR xxx`

- Bit 7:** (`PON` - Power On), operating readiness and interface activities of the interfaces are displayed on 1.
- 6:** (`URQ` - User Request), is not used, is always set on \emptyset .
- 5:** (`CME` - Command Error), is set on 1 at instruction errors.
- 4:** (`EXE` - Execution Error), is set on 1 at query errors and execution errors.
- 3:** (`DDE` - Device Dependent Error), device errors are displayed on 1.
- 2:** (`QYE` - Query Error), is set on 1 at question errors.
- 1:** (`RQC` - Request Control), is not used, is always set on \emptyset .
- \emptyset :** (`OPC` - Operation Complete), is set on 1 by transmitting the command `*OPC`.

ESE - EVENT STATUS ENABLE REGISTER

- Various statuses and settings of the RLC 100 can be checked. For this the contents of the ESR register are called with the help of a mask. The single bits are compared and evaluated by the following logical equation:

$$\text{ESB} = (\text{ESR7} \wedge \text{ESE7}) \vee (\text{ESR6} \wedge \text{ESE6}) \vee (\text{ESR5} \wedge \text{ESE5}) \vee (\text{ESR4} \wedge \text{ESE4}) \vee (\text{ESR3} \wedge \text{ESE3}) \vee (\text{ESR2} \wedge \text{ESE2}) \vee (\text{ESR1} \wedge \text{ESE1}) \vee (\text{ESR}\emptyset \wedge \text{ESE}\emptyset)$$

The result ESB (Event Summary Bit) is entered in the STB register.

- The command *ESE xxx offers the possibility of initializing the ESE register with any mask. The value xxx has to be within the range of \emptyset to 255. Otherwise the error VAL. OUT OF RANGE is reported.
- The current contents ESE xxx are saved in the output buffer by transmitting the command *ESE?. The contents of the register can set on \emptyset when switching on the RLC 100, by transmitting the command *ESE \emptyset or after changing the interface parameters.

7.2.1.2 STB - STATUS BYTE REGISTER

The contents of the STB register are filed in the output buffer by transmitting the command *STB? by the personal computer. The STB register can be set on \emptyset (except bit 4 - MAV) when switching on the unit, by transmitting the command *CLS or after changing the interface parameters.

Contents of the STB register: STB xxx

- Bit 7: is not used, is always set on \emptyset .
- 6: (MSS - Master Summary Bit), result during checkup of the STB register with a mask (SRE register).
- 5: (ESB - Event Summary Bit), result during checkup of the ESR register with a mask (ESE register).
- 4: (MAV - Message Available), is set on 1 if a current message of the RLC 100 is requested at the output buffer.
- 3: is not used, is always set on \emptyset .
- 2: is not used, is always set on \emptyset .
- 1: is not used, is always set on \emptyset .
- \emptyset : is not used, is always set on \emptyset .

SRE - SERVICE REQUEST ENABLE REGISTER

- Various statuses and settings of the RLC 100 can be checked. For this the contents of the ESR register are called with the help of a mask. The single bits (except SRE bit 6, which is always set on \emptyset) are compared and evaluated by the following logical equation:

$$\text{MSS} = (\text{STB7} \wedge \text{SRE7}) \vee (\text{STB5} \wedge \text{SRE5}) \vee (\text{STB4} \wedge \text{SRE4}) \vee (\text{STB3} \wedge \text{SRE3}) \vee (\text{STB2} \wedge \text{SRE2}) \vee (\text{STB1} \wedge \text{SRE1}) \vee (\text{STB}\emptyset \wedge \text{SRE}\emptyset)$$

The result MSS (Master Summary Status) is entered in the STB register.

- The command *SRE xxx offers the possibility of initializing the ESE register with any mask. The value xxx has to be within the range of 0 to 255. Otherwise the error VAL. OUT OF RANGE is reported.
- The current contents xxx are saved in the output buffer by transmitting the command *SRE?. The contents of the register can be set on 0 when switching on the RLC 100, by transmitting the command *SRE 0 or after changing the interface parameters.

7.2.2 Description of Results

- R measurement and absolute tolerance measurement of R: from OHM VX.XXXEUXX
to OHM VXXXXEUXX
- L measurement and absolute tolerance measurement of L: from H VX.XXXEUXX
to H VXXXXEUXX
- C measurement and absolute tolerance measurement of C: from F VX.XXXEUXX
to F VXXXXEUXX
- Relative tolerance measurement of R, L and C: VX.X or VYX.X or VZXX.X
- Q and D measurement: from VX.XXXEUXX
to VXXXXEUXX

Where:

X:	character from 0 to 9
Y:	character from 1 to 9
Z:	character from 1 to 2
U:	sign “+” oder “-”
V:	sign “-” or none

7.2.3 Description of Errors

- When errors occur in the remote-controlled settings and measurements, they are saved with a code in the error register. The contents (error message) of the error register are called and deleted by transmitting the command ERR? at any time.
- If several errors arise only the error codes of the first and last error are saved. On repeating transmission of the command ERR? the contents of the error codes are filed in the output buffer and initialized (deleted). The initializing of the error register is also started by transmitting the command *CLS (initializing of the state register).

Note: Before the transmission of the command ERR? the interface command DCL has to be send.

7.2.3.1 DER - DEVICE ERROR REGISTER

The contents of the DER register specifies the device error in the error register and is filed in the output buffer by transmitting the command DER?. The contents of the register are not deleted after reading.

Contents of the DER register: DER xxx

- Bit 7: is not used, is always set on 0.
- 6: is not used, is always set on 0.
- 5: is not used, is always set on 0.
- 4: is not used, is always set on 0.
- 3: (Overflow), is set on 1 when the measuring range is full.
- 2: (Out of RNG), is set on 1 when the value is out of range.
- 1: is not used, is always set on 0.
- 0: is not used, is always set on 0.

When a device error occurs the bit ESR3 (DDE) of the ESR register is set on 1.

- After following commands the DER register is set on 0:
 - settings of measuring functions (See 7.3.2),
 - switching on and off the correction of residual parameters of the terminals (TRIM_ON, TRIM_OFF),
 - starting the measurement (MEAS, MEAS?, TRIM_ON, REF),
 - initialization of instrument functions (*RST).
- The DER register is updated after completion and evaluation of the measurement.

7.2.3.2 Error Messages

The error messages (See Table 5) are dependent on the operating status and the type of error. At local control interface errors are displayed for only a short time. At remote control of the RLC 100 interface errors are displayed until the contents of the error register are queried or initialized.

Device errors are displayed until new commands from the personal computer are transmitted.

Error code	Text of messages	Meaning of text
∅	- DEVICE ERROR	- faultless operation device error
	DEVICE DEPENDENT ERROR	error in the device functions
1∅	OVERFLOW	- input buffer is overflown
2∅	OUT OF RNG	- value is out of range
	INTERFACE ERROR	interface error
	QUERY ERROR	query error
12∅	BAD USING QUERY	- used query is wrong
	EXECUTION ERROR	execution error
131	NO EXECUTION	- cannot be executed
132	NOT EX. IN LOCAL	- cannot be executed in local control
133	NO VALID DATA	- data are invalid
134	VAL. OUT OF RANGE	- value is out of range
	COMMAND ERROR	command error
151	ILLEGAL COMMAND	- illegal command
	RS 232 error	error of the RS-232C interface
181	INP. BUFFER FULL	- input buffer is full

Table 5: List of error messages

7.3 List of Commands on Remote Control

7.3.1 General Commands

- REN (Remote) - transition from local control to remote control
ASCII: HT = 9 (dec.)
- LLO (Locked Local Out) - locking of the LOCAL button
ASCII: EM = 25 (dec.)
- GTL (Go To Local) - transition from remote control to local control
ASCII: SOH = 1 (dec.)
- DCL (Device clear) - initializing for the communication protocol of the interface,
resetting or initializing of the partial circuits
ASCII: DC4 = 20 (dec.)

Note: The command DCL has no influence on the function of the device. These have to be initialized by the general command *RST.

*RST (Reset)	<ul style="list-style-type: none"> - initializing of unit settings (starting state) Measuring mode: - resistance measurement Selection of range: - automatically (AUTO) Polarisation voltage: - switched off Compensation of residual capacity: - switched off Reference value: - none Baud rate: - 9600 Bd Interface protocol: - none (NONE)
Note:	<p>After switching on the RLC 100 the commands DCL and *CLS are executed automatically and the contents of the ESE and SRE register are reset. Bit 7 (PON) of the ESR register is set on 1.</p>
*TST? (Test)	<ul style="list-style-type: none"> - start of internal test and saving of results meaning: Ø - test is successful 1 - test is not successful
*IDN? (Identification)	<ul style="list-style-type: none"> - identification GRUNDIG, RLC 100, x, y with x - production number or Ø y - software version or Ø
Note:	<p>The command *IDN? should be written at the end of the command line because subsequent data can be lost before transmission. Otherwise the error BAD USING QUERY is reported.</p>
*CLS (Clear Status Byte)	<ul style="list-style-type: none"> - resetting of ESR- and STB register (except bit 4 - MAV) Initializing of the error structure (See 7.2.3), ESE- and SRE register are not deleted.
*WAI (Waiting)	<ul style="list-style-type: none"> - The following commands are executed only after completion of current operation.
*OPC (Operation Complete)	<ul style="list-style-type: none"> - After completion of current operation bit Ø (OPC) in the ESR register is set on 1.
*OPC?	<ul style="list-style-type: none"> - After completion of current operation the number 1 is saved in the output buffer.
ERR? (Error)	<ul style="list-style-type: none"> - reading and resetting of the error messages (See 7.2.3)
DER?	<ul style="list-style-type: none"> - Contents of the DER register are filed in the output buffer.
*ESR?; *ESE xxx; *ESE?	<ul style="list-style-type: none"> - reading and resetting of the ESR (See 7.2.1.2)
*STB?; *SRE xxx; *SRE?	<ul style="list-style-type: none"> - reading and resetting of the STB (See 7.2.1.2)

7.3.2 Commands and Messages

Setting of the operating mode (See 6.3)

MODE_R	- resistance measurement [Ω]
MODE_RDA	- absolute tolerance measurement of the resistance [Ω]
MODE_RDR	- relative tolerance measurement of the resistance [%]
MODE_QR	- quality measurement of the resistance [-]
MODE_L	- inductance measurement [H]
MODE_LDA	- absolute tolerance measurement of the inductance [H]
MODE_LDR	- relative tolerance measurement of the inductance [%]
MODE_QL	- quality measurement of the inductance [-]
MODE_C	- capacitance measurement [F]
MODE_CDA	- absolute tolerance measurement of the capacitance [F]
MODE_CDR	- relative tolerance measurement of the capacitance [%]
MODE_DC	- loss factor measurement of the capacitance [-]
MODE?	- Current measuring function MODE_??? is filed in the output buffer.

Selection of the automatic measuring range

RANGE_AUTO	- selection of the automatic measuring range
RANGE_HOLD	- Switching off the selection of the automatic measuring range, the last current measuring range is retained.
RANGE?	- Current measuring range selection RANGE_AUTO or RANGE_HOLD is filed in the output buffer.

Setting the voltage polarization at the measuring socket

BIAS_ON	- switching on the polarization voltage
BIAS_OFF	- switching off the polarization voltage
BIAS?	- Current setting of the polarization voltage BIAS_ON or BIAS_OFF is filed in the output buffer.

Setting to compensate the residual capacity at the measuring socket

TRIM_ON	- measuring the residual capacitance The residual capacitance of the measuring socket is subtracted from the measured capacitance of the measuring object (See 6.5.1).
---------	---------------------------------------------------------------------------------------------------------------------------------------------------------------------------

Note: If the residual capacitance $C \geq 100$ pF, the error OVERFLOW appears on the display [3].

TRIM_OFF - clearing the value of the residual capacitance
TRIM? - Present setting to compensate the residual capacitance TRIM_ON or TRIM_OFF is filed in the output buffer.
If the measuring function is set to R or L measurement, the message TRIM_NONE is filed in the output.

Note: If the measuring function is set to R or L measurement, the error message NO EXECUTION appears on the display [3].

Entering the reference values for the tolerance measurement

REF - measuring the input parameter
The measurement result is saved according to the selected measuring function as reference value REF R, REF L or REF C.

Note: If the reference value is outside the measuring range, the error message OUT OF RNG or OVERFLOW appears on the display [3] and the reference value will not be saved.
If measuring functions other than R, L, C measurements are set, the error message NO EXECUTION appears on the display [3].

REF_DEC - The reference value is reduced by one unit of resolution of the measuring range. The minimum setting value is $0001 \times$ resolution of the measuring range.

REF_INC - The reference value is increased by one unit of resolution of the measuring range. The maximum setting value is $1999 \times$ resolution of the measuring range.

Note: If the minimum or maximum setting value is reached, the error message VAL. OUT OF RANGE appears on the display [3].

REF? - Current reference value, e.g. OHM 25.7E+03, of the selected measuring function is filed in the output buffer.

Starting of the measurement without transmission of the measuring results

MEAS - measurement of the input parameters
The measured value is filed in the output register.
READ? -The measured value in the output register is filed in the output buffer.

Note: If the measuring value is not filed in the output buffer, the error message NO VALID DATA appears on the display [3].

Starting of the measurement with transmission of the measuring results

MEAS? - measurement of the input parameters
The measured value is filed in the output buffer.

7.4 Measurement by Remote Control

- For remote control of the RLC 100 the connecting cable of the serial interface RS-232C has to be connected before switching on the operating voltage. After switching on the RLC 100 is in starting position and can receive commands. The remote control is displayed on LED *REM* [11].
- It should be noted that single commands and device commands have to be separated by a semicolon (ASCII: ; = 59) and finished by the end character (See Table 6). Certain commands or messages can contain parameters or measuring results which are separated by a separation character (See Table 6) from the command.
- Single commands can be written one after the other in one command line, the length of which may not exceed 64 characters. In case errors occur, the command sequence is ignored and error `INP . BUFFER FULL` is indicated.

	Reception	Transmission
Separation characters	SP = 32 (dec.) NUL = 0 (dec.) STX to BS = 2 to 8 (dec.) VT to DC3 = 11 to 19 (dec.) NAK to CAN = 21 to 24 (dec.) SUB to US = 26 to 31 (dec.)	SP = 32 (dec.)
End characters	LF = 10 (dec.)	CR + LF = 13 + 10 (dec.)

Table 6: Separation and end characters

7.5 Program Example (Q-Basic)

```
10 REM *****
20 REM THE EXAMPLE OF USING RLC 100 WITH RS-232C INTERFACE
30 REM BAUD RATE 9600 Bd
40 REM RESISTANCE MEASUREMENT
50 REM *****
60 REM CLS
70 REM *** ACTIVATE INTERFACE ***
80 IDCL$=CHR$(20):IREN$=CHR$(9):ILLO$=CHR$(25):IGTL$=CHR$(1)
90 REM
100 REM *** CONFIGURATE INTERFACE ***
110 OPEN "com2:9600,n,8,1,CS30000,LF" FOR RANDOM AS #1
120 REM
130 REM *** ACTIVATE UNIT ***
140 PRINT #1,IDCL$;IREN$;ILLO$;"*RST;*CLS"
150 REM
160 REM *** SET OPERATING PARAMETERS ***
170 PRINT #1,"MODE_R"
180 REM
190 REM *** STARTING OF MEASUREMENT ***
200 PRINT #1,"MEAS?"
210 REM
220 REM *** RECEIVING AND DISLAYING OF MEASURED VALUES ***
230 INPUT #1,A$
240 PRINT #1,"Any resistance values:",A$
250 REM
260 REM *** TRANSITION TO LOCAL CONTROL ***
270 PRINT #1,"*OPC?"
280 INPUT #1,A$
290 PRINT #1,IGTL$
300 REM
310 REM *** CLOSE STATEMENT ***
320 CLOSE #1
330 END
```

8 Maintenance

The RLC 100 does not require special maintenance if it is used and handled correctly.

Only use a soft wet rag with some soap suds or a soft rinse liquid for cleaning. Avoid acrid cleanser and solvents.

Service work should only be done by trained personnel.

In case of repairs it is vital to ensure that the design features of the RLC 100 are not changed, resulting in a reduction in operational safety, and that replacement parts match the original ones and are installed properly (original state).



Warning!

The RLC 100 must be separated from all power sources before maintenance work is carried out and before parts or fuses are repaired or replaced.

9 Appendix

9.1 Declaration of Conformity

<i>digimess</i>	Konformitätserklärung Declaration of Conformity / Déclaration de Conformité 130/96	CE
Der Hersteller/Importeur The manufacturer/importer Le producteur/importateur	<i>digimess</i> Professional Electronics GmbH	
Anschrift / Address / Adresse	Würzburger Straße 150 90766 Fürth Germany	
erklärt hiermit eigenverantwortlich, daß das Produkt: declare under their sole responsibility that the product: / déclare, que le produit:		
Bezeichnung / Name / Description	Programmierbares automatisches RLC-Meter Programmable automatic RLC Meter RLC-mètre automatique programmable	
Type / Model / Type	RLC 100	
Bestell-Nr. / Order-No. / NO de réf.	H.UC 31-00	
folgenden Normen entspricht: is in accordance with the following specifications: / correspond aux normes suivantes:		
EN 61010-1 (1994)		
DIN EN 50081-1 (1993) DIN EN 50081-2 (1994)		
EN 55011 (1991) Class B		
EN 55022 (1987) Class B		
Das Produkt erfüllt somit die Forderungen folgender EG-Richtlinien: Therefore the product fulfils the demands of the following EC-Directives: Le produit satisfait ainsi aux conditions des directives suivantes de la CE:		
73/23/EWG	Richtlinie betreffend elektrische Betriebsmittel zur Verwendung innerhalb bestimmter Spannungsgrenzen Directive relating to electrical equipment designed for use within certain voltage limits Directive relatives au matériel électrique destiné à être employé dans certaines limites de tension	
89/336/EWG	Richtlinie über die elektromagnetische Verträglichkeit Directive relating to electromagnetic compatibility Directive relatives à la compatibilité électromagnétique	
Fürth, 4.4.1996	 Henninger <i>Leiter Qualitätsmanagement</i> <i>Q-Manager / Directeur Contrôle de Qualité</i>	